

# MACTECH DIAMOND WIRE SAWS

MACTECH OFFSHORE PORTABLE MACHINING SOLUTIONS

## Subsea and Toplevel Multi-String Casing and Structure Cutting

### Diamond Wire Saw Features

- Use for cutting multi-string casing, structures, and any large, heavy material. All models can cut in any orientation.
- Models available to cut 4-1/2 to 102 inch pipe and structures.
- Rigid frames makes repeatability and back-cutting easier and more accurate.
- Powerful drives cut through the toughest steel and aggregates, with less hang-ups.
- Compact and lightweight designs takes less deck space and reduces excavation for BML cuts.
- Continuous loop diamond wire resists breaking, makes multiple cuts with a single wire. Cuts faster and lasts longer than electroplated/sintered wire.

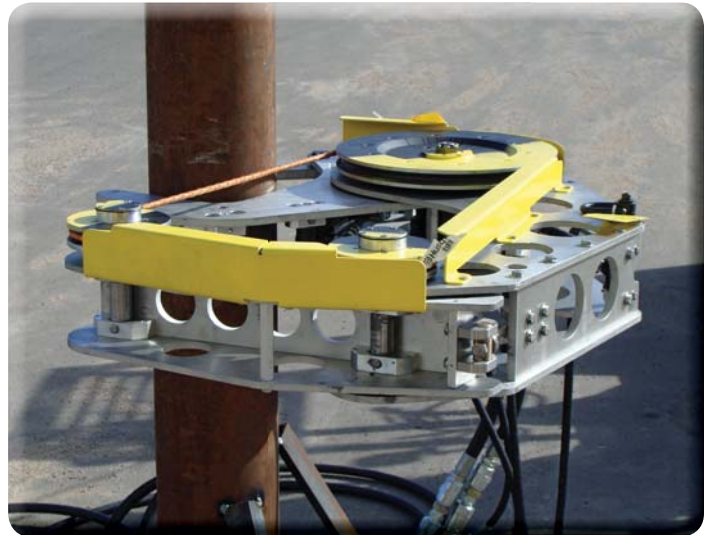

*DWS-16co Cut-off Saw*

**Mactech offers a range of Diamond Wire Saws for subsea and topside cutting** of a variety of materials and projects. Ideal for cutting multi-string applications or heavy wall legs and cross members. Typical uses include offshore decommissioning, and subsea or topside maintenance. The compact and robust design creates an ideal cutting environment, reducing setup, installation, and removal time – saving you time and money.

Find the saw you need knowing Mactech diamond wire saws are easily customized and adaptable to specific project needs. Our versatile range includes the ultra-compact and lightweight DWS-16co, to the large diameter capacity DWS-102i. The unique DWS-40a articulating diamond wire saw is designed for below-the-mudline or low clearance cuts. ROV compatibility allows for deepwater cutting and maintenance. All of Mactech's Diamond Wire Saws are designed to give you maximum cutting range flexibility, small footprint and reliable operation.



*Multi-String Cut made with Mactech's DWS-26i Diamond Wire Saw*



# MACTECH DIAMOND WIRE SAWS

MACTECH OFFSHORE PORTABLE MACHINING SOLUTIONS

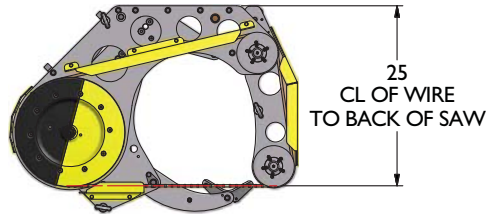

**DWS-16co 16 inch Cut-off Saw**

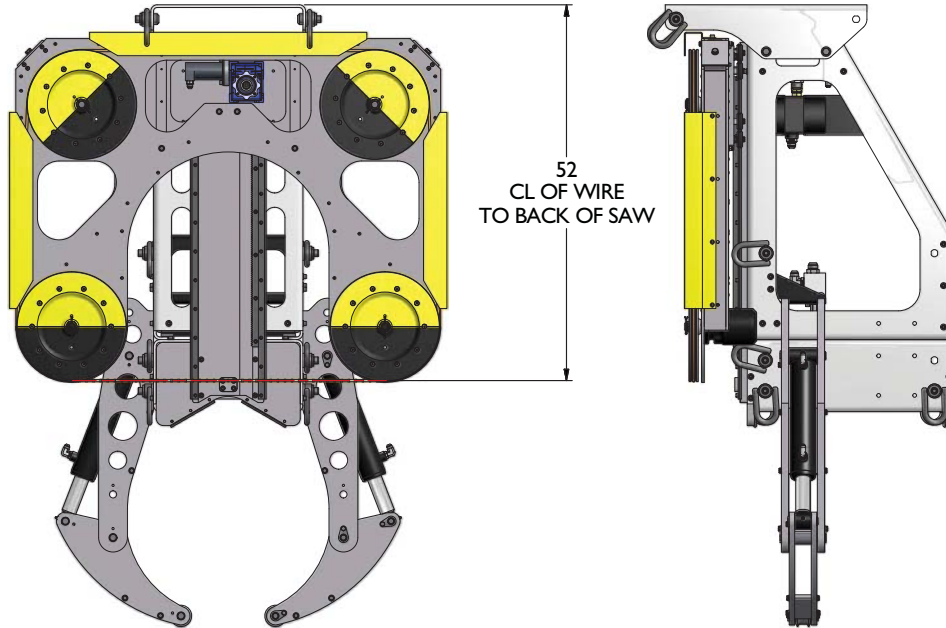

**DWS-26i 26 inch Inline Saw**

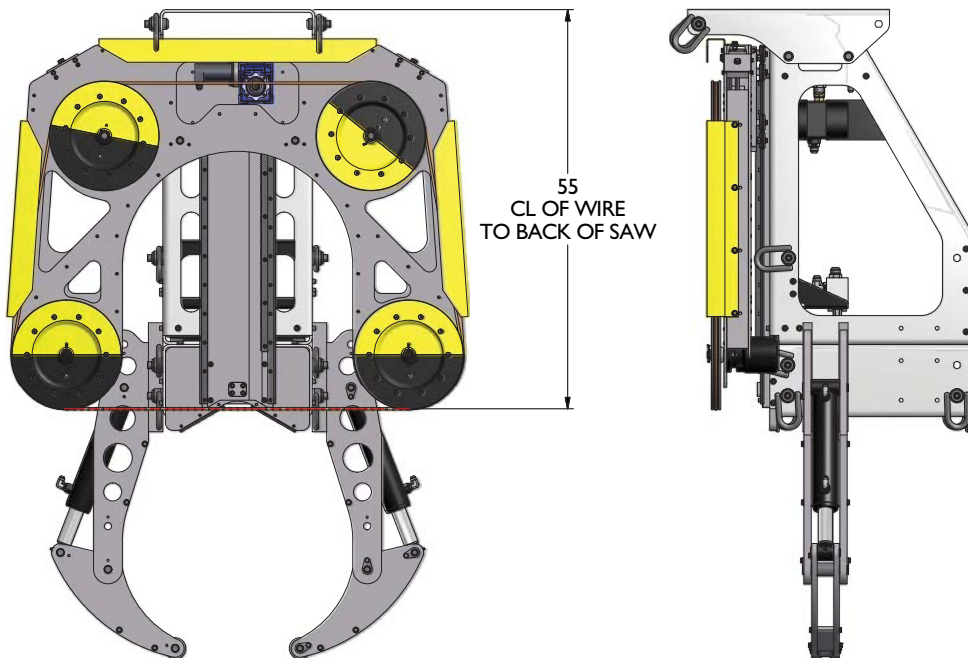

**DWS-30i 30 inch Inline Saw**

# MACTECH DIAMOND WIRE SAWS

MACTECH OFFSHORE PORTABLE MACHINING SOLUTIONS

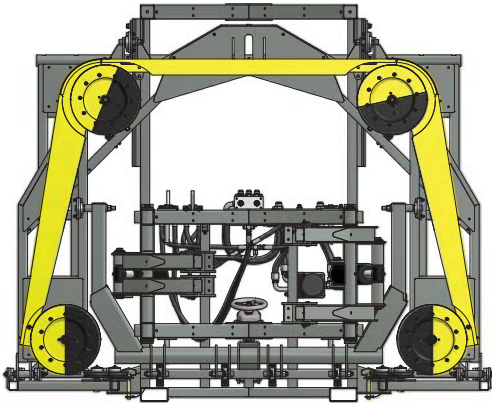
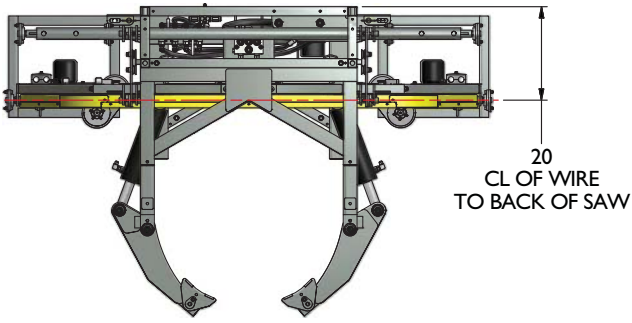

**DWS-40a 40 inch Articulating Saw**

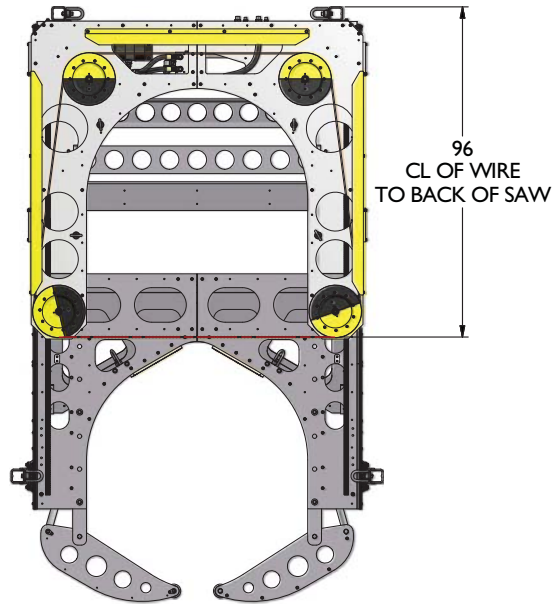

**DWS-60i 60 inch Inline Saw**

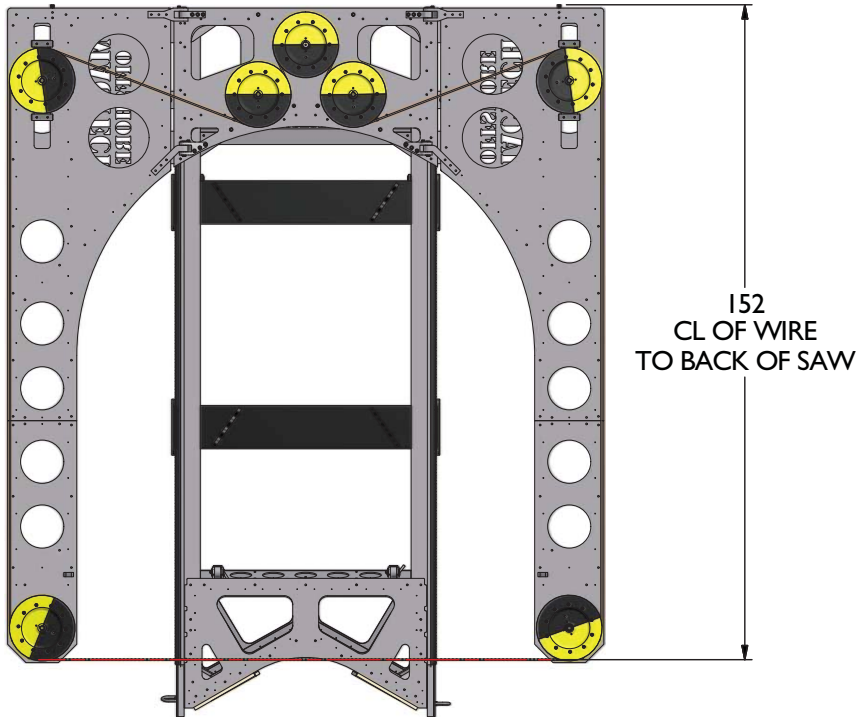

**DWS-102i 102 inch Inline Saw**



# MACTECH DIAMOND WIRE SAWS

MACTECH OFFSHORE PORTABLE MACHINING SOLUTIONS

Model	DWS-16co Cut-off Saw	DWS-26i Inline Frame	DWS-30i Inline Frame	DWS-40a Articulating Frame	DWS-60i Inline Frame	DWS-102i Inline Frame
<b>Clamp Capacity Diameter</b>	4-1/2 to 16 inches	8 to 26 inches	16 to 30 inches	22 to 40 inches	26 to 60 inches	48 to 102 inches
<b>Operating Dimensions (LxWxH)</b>	43 x 24 x 10 inches	86 x 61 x 40 inches	86 x 65 x 40 inches	86 x 107 x 55 inches	165 x 98 x 55 inches	165 x 138 x 69 inches
<b>Shipping Dimensions (LxWxH)</b>	60 x 48 x 36 inches	86 x 61 x 43 inches	86 x 65 x 43 inches	86 x 107 x 60 inches	145 x 98 x 33 inches	165 x 60 x 73 inches
<b>Operating Weight</b>	210 lbs	1025 lbs	1050 lbs	2400 lbs	2575 lbs	2375 lbs
<b>Shipping Weight</b>	650 lbs	1325 lbs	1350 lbs	2550 lbs	2575 lbs	2450 lbs

All Diamond Wire Saw services include spare parts kit and control cart. Hose reels and hydraulic power supplies are also available.



**Spare Parts Kit**



**Control Cart**



Mactech, Inc. • 214 Southpark Rd. • Lafayette, LA 70508  
 PH: 337-839-2793 • TOLL FREE: 800-328-1488 • FAX: 337-839-2794 • [www.mactechonsite.com](http://www.mactechonsite.com)